



# **GT-1 (Temperature) Sensor Manual**

57-6039 Rev D

This page intentionally left blank.

# Contents

<b>1.0 NOTICES.....</b>	<b>5</b>
1.1.1 © Copyright 2021 Dyacon, Inc.....	5
1.1.2 Manufacturer.....	5
1.1.3 Declarations.....	6
1.1.4 Warranty Information.....	6
<b>2.0 GT-1 INTRODUCTION.....</b>	<b>8</b>
2.1 Scope.....	8
2.2 Technical Support.....	8
2.2.1 Contact Information.....	8
2.2.2 Phone / Email Support.....	8
<b>3.0 PRODUCT OVERVIEW.....</b>	<b>9</b>
3.1 Product Description.....	9
3.2 What Do You Get?.....	10
3.3 What You Need.....	10
3.4 Accessories.....	11
<b>4.0 ASSEMBLY INSTRUCTIONS.....</b>	<b>12</b>
4.1 Required Tools.....	12
4.2 Mounting Bracket.....	12
4.3 Wiring.....	13
<b>5.0 MODBUS.....</b>	<b>14</b>
5.1 Modbus Summary.....	14
5.2 Modbus Utilities.....	14
5.3 Modbus Electrical Connection.....	15
5.3.1 Bus Connection.....	15
5.3.2 Termination and Biasing.....	15
5.4 Modbus Commands.....	16
5.4.1 Measurement Registers.....	16
5.5 Data Format.....	19
5.5.1 Temperature Format.....	19
5.6 Conversions and Calculations.....	20
5.6.1 Temperature Conversion.....	20
<b>6.0 WET-BULB GLOBE TEMPERATURE.....</b>	<b>21</b>
6.1.1 Wet-bulb Calculation.....	21
6.1.2 Web-bulb Globe Temperature Calculation.....	22
<b>7.0 THEORY OF OPERATION.....</b>	<b>23</b>
7.1 Sensors.....	23
7.1.1 Temperature.....	23
7.2 Electrical Architecture.....	23
<b>8.0 POWER SAVING.....</b>	<b>24</b>
8.1 Run Timeout Power.....	24
8.2 Wake and Sleep Operation.....	24
8.3 Power Down.....	25
<b>9.0 SOFTWARE.....</b>	<b>26</b>

- 9.1 Introduction.....26
- 9.2 Boot Loader.....26
  - 9.2.1 Required Equipment.....26
  - 9.2.2 Procedure.....26
- 10.0 REPAIR AND SERVICE.....27**
  - 10.1 Repair and Calibration.....27
- 11.0 SPECIFICATIONS.....28**
- 12.0 MODBUS APPENDIX.....29**
- 13.0 REVISION HISTORY.....31**

# I.0 NOTICES

## 1.1.1 © Copyright 2021 Dyacon, Inc.

### All Rights Reserved

This publication is protected by copyright and all rights are reserved. Any reproduction of this manual, in part or in full, by any means, mechanical, electronic, or otherwise, is strictly prohibited without express written permission from Dyacon, Inc.

The information in this manual has been carefully checked and is believed to be accurate. However, Dyacon, Inc. assumes no responsibility for any inaccuracies that may be contained in this manual. All information is subject to change.

### Trademark Acknowledgments

Dyacon® and Dyacon® is a registered trademark of Dyacon, Inc.

Dyacon, GT-1™, GT™ are trademarks of Dyacon, Inc.

All other trademarks are property of their respective owners.

## 1.1.2 Manufacturer

Dyacon, Inc.

### 1.1.3 Declarations

Dyacon GT-1™ is a low-power electronic industrial device.

#### RoHS

All electronic and mechanical components conform to RoHS, Directive 2002/95/EC.

#### FCC CFR Part 15

This equipment complies with the limits for a Class A digital device, pursuant to part 15 of the FCC Rules. These limits are designed to provide reasonable protection against harmful interference in a commercial installation.

### 1.1.4 Warranty Information

#### Limited Hardware Warranty

Dyacon, Inc. warrants that all Dyacon products and components shall be free from defects in materials and workmanship for a period of one (1) year from the date of shipment when installed according to instruction manuals accompanying said hardware and used for the purpose for which said hardware was designed. In the event a defect in materials or workmanship is discovered and reported to Dyacon within the warranty period, Dyacon will at its option repair the defect or replace the defective product. This warranty does not apply where the product has been operated outside the specifications of the product. Dyacon's obligation hereunder will be limited to such repair or replacement. Customers shall have the responsibility to ship the defective equipment to Dyacon at its (customer's) expense, with all cost of shipment prepaid. Dyacon will ship the repaired or replaced item at its (Dyacon's) expense using the preferred shipment method of Dyacon.

#### Disclaimer of Warranties

The warranties set forth above are in lieu of all other warranties of Dyacon, whether written, oral, or implied. Dyacon makes no warranties regarding its products (hardware or software), including without limitation warranties as to merchantability, fitness for a particular purpose, any warranty arising from course of performance, course of dealing or usage of trade whether any of the foregoing warranties are either expressed or implied. Dyacon specifically makes no warranties as to the suitability of its products for any particular application. Dyacon shall in no event be liable for performance, or use of any product covered by this agreement whether such claim is based upon warranty contract (express or implied), strict liability, negligence, or otherwise. Any responsibility and/or liability of Dyacon shall, in connection with a warranted product, be limited in maximum amount to the original purchase price of that product.

#### Removal of Serial Number

Removal of the original serial number label or reprogramming of the electronic serial number voids any warranty on the device. Dyacon will not repair or update products if the serial number label missing or legitimate ownership cannot be verified. Dyacon may not return equipment that is missing serial numbers or where legitimate ownership is in question.

#### Updates or Modifications

Dyacon shall be under no obligation to update or modify its products except as herein noted to correct defects or errors. Customer agrees that all representation and warranties contained herein shall be immediately null and void in the event of any incorrect installation, modification,

alteration, or change in or to any product affected by or on behalf of customer except for a change made by Dyacon or other direct supervision thereof.

---

## 2.0 GT-1 INTRODUCTION

---

### 2.1 Scope

The content of this document is intended for integrators, installers, and users of GT-1™.

This document includes installation instructions, technical specifications, electrical requirements, and data protocol information. Some aspects of the equipment operation may be covered in other documents. Please contact Dyacon or visit the [Dyacon.com](http://Dyacon.com) website.

---

### 2.2 Technical Support

#### 2.2.1 Contact Information

Dyacon, Inc.

Phone: (435) 753-1002

Email: [support@dyacon.com](mailto:support@dyacon.com)

Internet: [www.Dyacon.com](http://www.Dyacon.com)

Normal business hours are from 9:00 am to 5:00 pm. (Mountain Time Zone, GMT -0700)

#### 2.2.2 Phone / Email Support

If you need technical support via the phone or email, please have the following information ready:

Product name, model number, and serial number.

Your name and name of the purchaser of the equipment.

Name of company, institution, or agency.

Phone number, email address.

Billing and Shipping address.

A clear description of the question or problem.



# 3.0 PRODUCT OVERVIEW

---

## 3.1 Product Description

Dyacon GT-1™ is a globe temperature instrument. It may be used as a standalone sensor, a component of Dyacon weather station, or integrated into other automated equipment.

GT-1 is a digital sensor, sending instrument data and receiving control commands via a digital serial port using Modbus-RTU protocol over TIA-485-A (RS-485). Consequently, there is no measurement degradation due to cable length.

GT-1 is easily mounted to the end of a 1” pipe using simple tools and standard structural pipe fittings.

### Sensor Protocol Descriptions

Modbus-RTU (RS-485) is an electrically robust protocol used in automation systems, such as programmable logic controllers (PLCs). GT-1 uses a default data rate of 19200 bps, ensuring adequate data throughput while extended cable length capability.

A thermistor version is available as GT-2.

Additional firmware and customization options are also available to VARs. Contact Dyacon, Inc. for more information.

### Mechanical Design

The mechanical design for GT-1 was designed to meet the following objectives.

- Minimize installation hardware and complexity – The sensor may be slipped over a 3/4” pipe or used with standard 1” structural pipe fittings.
- Minimize cable routing vulnerability – The cable can be routed directly adjacent to or inside of the mounting pipe.
- Maintain mechanical simplicity – The system can be easily disassembled and repaired in the field.
- Provide – A full copper sphere is used to provide intended thermal characteristics of a globe temperature sensor.
- Polyester Coating – The black coating provides maximum protection when mounted permanently out of doors.

---

## 3.2 What Do You Get?

GT-1 ships with:

Globe assembly and cable ties.



*Image 3.1: GT-1, As-shipped*

---

## 3.3 What You Need

In order to utilize the GT-1 you will need the following.

1" diameter mounting pipe (aluminum, steel, or PVC, 1.32 inch actual outer diameter).

5 to 24 VDC power supply.\*

Modbus host device.

---

## 3.4 Accessories

### Structural Pipe Fittings

Standard structural pipe fittings for 1" schedule 40 pipe are available from hardware suppliers and manufacturers.

Hollaender Nu-Rail ([www.nurail.com](http://www.nurail.com))

J.C. Denier ([www.denierco.com](http://www.denierco.com))

Easyfit ([www.easyfit.com](http://www.easyfit.com))

Diamond Aluminum ([www.diamond-aluminum.com](http://www.diamond-aluminum.com))

KEE Systems ([www.keesystems.com](http://www.keesystems.com))

McMaster-Carr ([www.mcmaster.com](http://www.mcmaster.com))

Grainger ([www.grainger.com](http://www.grainger.com))



# 4.0 ASSEMBLY INSTRUCTIONS

---

## 4.1 Required Tools

No tools required.

Tools only required for mounting, which is depending on the users mounting system.

---

## 4.2 Mounting Bracket

The mounting bracket is designed to fit on a 1" schedule 40 pipe, with 1" NPT thread. The nominal OD is 1.315".

The supplied PVC pipe can be easily drilled to route the cable through the side of the pipe if necessary.

Observe wire route to avoid cutting or pinching the cable when mounting.



*Image 4.1: Mounted showing mounting pipe.*

## 4.3 Wiring

GT-1 ships with shielded, 4-conductor, outdoor-rated instrumentation cable.

Red – 5 to 24 VDC

Orange – A (+)

Brown – B (-)

Black – Electrical ground

Bare – Earth Ground (Shield)

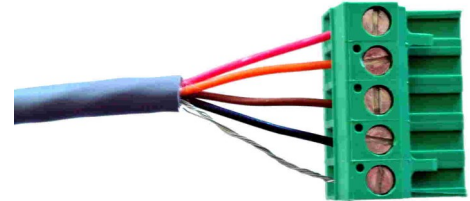

*Image 4.2: Wired for Dyacon Control Module*

# 5.0 MODBUS

---

## 5.1 Modbus Summary

Modbus is a simple protocol that can be transmitted over several modes including TCP/IP, TIA-232-A (RS-232), TIA-485-A (RS-485), TCP/IP, SMS, and many others.

Dyacon GT-1 uses Modbus-RTU over RS-485.

GT-1 is a slave device and must be connected to a host device, such as a programmable logic controller (PLC), host computer with an RS-485 adapter and Modbus software, or to the Dyacon weather station control module.

RS-485 is a robust, differential pair electrical protocol that is noise immune and capable of long cable runs. With twisted pair cabling, such as CAT-5, distances over 1200 m (4,000 ft) can be achieved. GT-1 can be configured for 1200 bps or 2400 bps to extend the range. Relatively long runs are achievable even without twisted pair cables.

The wide operating voltage range and low power of GT-1 allows for power to be injected over the same data cable without concern for excess voltage drop. (Two wires for power and two for data.)

For example, 1200 m (4000 ft) of Cat-5 cable (24 AWG) will result in a voltage drop of less than 0.2 V at an operating current of 2 mA.

GT-1 ships standard with 2 m (6.5 ft) of non-paired cable.

---

## 5.2 Modbus Utilities

The address of the sensor and other parameters are configurable. A Modbus computer utility may be required to change these settings. A number of utilities are available including:

ModBusConstructor by KurySoft ([www.kurysoft.com](http://www.kurysoft.com))

Simply Modbus ([www.simplymodbus.ca](http://www.simplymodbus.ca))

ModbusTools ([www.modbustools.com](http://www.modbustools.com))

Only ModBus Constructor and the companion Modbus Reader have been tested with the Dyacon product.

A list of Modbus software can be found at: [www.modbus.org/tech.php](http://www.modbus.org/tech.php)

## 5.3 Modbus Electrical Connection

### 5.3.1 Bus Connection

Dyacon devices use a two-wire (half-duplex) electrical connection.

The Modbus port is a slave port that can be connected to a Modbus Host or Master.

Pin 1 – RS-485 RX/TX+ (A)

Pin 2 – RS485 RX/TX- (B)

#### Connecting to 4-wire Master

When connecting the sensor to a 4-wire master, install a jumper between the RX+ and TX+ as well as between RX- and TX-. The Master device may have to be configured to operate in half-duplex mode. Refer to the instructions for your equipment for half-duplex and full-duplex settings.



### 5.3.2 Termination and Biasing

RS-485 (EIA-485) networks require a termination resistor of 120Ω. A termination resistor is not used on Dyacon sensors. Depending on the bus, a termination resistor may be needed. Additional bias resistors may also be needed.

Modbus is based on a bi-directional RS-485 data bus. Since the bus is bi-directional, anytime either the master or slave is not driving the bus, the bus floats. If the bus has termination resistors on it (as it should) the two lines will be at the same voltage if no other device is transmitting. While Dyacon equipment utilizes full fail-safe (Open, Short, Terminated/Floating) RS-485 transceivers, this is not the case with all equipment. Some equipment needs a bias on the RS-485 lines to prevent the bus from being interpreted as being active while it floats. This can be even more important in a noisy environment.

The following would be a common biasing and termination circuit. While this circuit works well in most situations, adjusting the resistors may be needed depending on the bus configuration, other termination resistors on the bus, and the operating voltage.

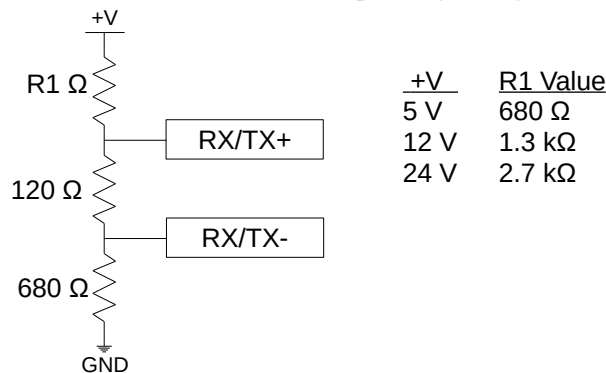

## 5.4 Modbus Commands

GT-1 is a Modbus slave device; the Modbus host must requests data from the sensor.

The following describes the Modbus commands and messages. The basic instructions should be adequate for Modbus host programming. For embedded developers, additional protocol details are contained in the Modbus Appendix.

The default configuration:

Modbus address            04  
 Serial Data Parameters   19200, 8-bit data, no parity, 1 stop bit

### Supported Functions and Exception Codes

Function	Description	Supported Error and Exception codes*
3	Read Holding Register	0x83: 01, 02, 03, 04
4	Read Input Register	0x84: 01, 02, 03, 04
6	Write Single Register	0x86: 01, 02, 03, 04
16	Write Multiple Registers	0x90: 01, 02, 03, 04

\* See Error Code table below for more information.

### 5.4.1 Measurement Registers

#### Standard Resolution Registers

Sensor data has both standard and high-resolution registers. Sensor specification apply only to the standard resolution registers.

Address	Register	Access Type	Response Range	Data Type	Description
200	201	Read	0 to 3	16-bit Signed Int	System Status†
201	202	Read	-400 to 1250*	16-bit Signed Int	Temperature (Celsius)

† See System Status Code section below.

\* See Data Format section for numeric conversions.

#### High Resolution Registers

Some activities, such calibration, may benefit from the high-resolution registers that fully expose the maximum capabilities of the sensing elements.

Address	Register	Access Type	Response Range	Data Type	Description
210	211	Read	-40.00 to 125.00	Float	Temperature (Celsius)



## Basic Configuration Messages

The following commands can be used to change the serial port parameters of the air sensor.

Address	Register	Access Type	Range	Data Type	Description
100	101	Read		16-bit Signed Int	MM = Product ID YY = Product Variation
101	102	Read		16-bit Unsigned Int	Serial Number
102	103	Read		16-bit Signed Int	Firmware Version
103	104	Read/Write	1-247 Default: 4	16-bit Signed Int	Modbus slave address.
104	105	Read/Write	0 = 1200 bps 1 = 2400 bps 2 = 4800 bps 3 = 9600 bps 4 = 19200 bps 5 = 38400 bps Default: 4	16-bit Signed Int	Baud rate.
105	106	Read/Write	0 = None 1 = Odd 2 = Even Default: 0	16-bit Signed Int	Parity
106	107	Read/Write	0 to 10,000 Default: 0	16-bit Signed Int	Run Timeout. Duration in ms before GT-1 returns to sleep. Zero (0) is full-run mode.*

\* Refer to Power Saving section for more details.

## Calibration Settings

Calibration values are entered as slope and offset (mx+b). The following calibration settings are user accessible.

Address	Register	Access Type	Default	Data Type	Description
110	111+112	Read/Write	1	32-bit Single-precision Float*	Temperature Slope
112	113+114	Read/Write	0	32-bit Single-precision Float	Temperature Offset

\* 32-bit single-precision floating point (IEEE-754) numbers are restricted to about 7 significant decimal figures. 32-bit values are transmitted most significant word (MSW) first.

## Error Codes

The following error and acknowledgment codes are supported by the GT-1. Not all codes are relevant to each request or command. Supported command error codes are listed for each command.

Function	Name	Description
01	Illegal Function	Function not supported or not recognized by the sensor.
02	Illegal Addresses	Incorrect address, address does not exist, or address does not support write function.
03	Illegal Data Value	Data value is outside of allowed range.
04	Device Failure	Error occurred while attempting to perform the requested action.

## System Status Codes

System status codes are unique to the sensor, not Modbus protocol exceptions. System codes are bit codes representing internal functional errors. A clear (0) bit indicates no errors were detected. A set (1) bit indicates an error.

Contact customer support if system errors are encountered.

### Hex Values

0x0000 – No Errors

0x0008 – Temperature CRC error

## 5.5 Data Format

GT-1 delivers instrumentation data as signed integers. Consequently, numeric conversion is required to determine the decimal values.

When GT-1 is used with Dyacon control modules, the instrument data is automatically presented in the form of standard units and ranges.

When GT-1 is used with a PLC or other host device, the instrumentation data will need to be numerically converted to conventional units.

### 5.5.1 Temperature Format

The measured temperature range is -40.0°C to 125.0°C.

The Modbus data range is -400 to 1250.

$$\text{Temperature (}^{\circ}\text{C)} = (\text{ModbusData}) / 10$$

The high-resolution registers use floating point values. No divide-by 10 operation is needed.

## 5.6 Conversions and Calculations

### 5.6.1 Temperature Conversion

Unit conversion can be done by utilizing the slope and offset feature or applying the following formulas to the GT-1 formatted data.

$$\text{Temperature (}^{\circ}\text{F)} = \text{Temperature}^{\circ}\text{C} * 1.8 + 32$$

---

#### **Conversion Tip**

GT-1 contains calibration registers that can be used for conversion. Just enter the desired conversion values shown above into the slope and offset registers for temperature.

Please be aware, that this may complicate any calibration adjustments that may have to be applied later.

---

# 6.0 WET-BULB GLOBE TEMPERATURE

Wet-bulb Globe Temperature (WBGT) is a relative scale that is associated with human body heat stress and takes into account radiant heat sources. GT-1 does not give WBGT, but it can be used in conjunction values from Dyacon TPH-1 to generate WBGT.

WBGT is a calculated value derived from globe temperature, wet-bulb temperature, and dry-bulb temperature. When GT-1 is combined with Dyacon TPH-1 the necessary values for WBGT calculation.

## 6.1.1 Wet-bulb Calculation

Wet-bulb temperature must be determined by using the dry air temperature and relative humidity measurements from Dyacon TPH-1 sensor. At a pressure of 1006 mbar, the follow formula will have a maximum error of 6%.

Temperature is in Celsius degrees.

$$T_{wet-bulb} = A * T_{dry} + B * rh + C * T_{dry}^2 + D * rh^2 + E * T_{dry} * rh + F$$

where:

$$A = 0.53913$$

$$B = 0.10478$$

$$C = -0.00074936$$

$$D = -0.0010774$$

$$E = 0.0064146$$

$$F = -5.1515$$

For snow making applications, the following formula from Mountain View Technologies ([www.the-snowman.com](http://www.the-snowman.com)) has been tested for the range of -18°C to 4°C.

Temperature is in Celsius degrees.

$$T_{wet-bulb} = (A + B * T_{dry} + C * T_{dry} * T_{dry} + (D + E * T_{dry} + F * T_{dry} * T_{dry}) * rh + (G + H * T_{dry} + I * T_{dry} * T_{dry}) * rh * rh)$$

where:

$$A = -5.806$$

$$B = 0.672$$

$$C = -0.006$$

$$D = 0.061$$

$$E = 0.004$$

$$F = 0.000099$$

$$G = -0.000033$$

$$H = -0.000005$$

$$I = -0.0000001$$

## 6.1.2 Web-bulb Globe Temperature Calculation

The following formula is used to calculate WBGT for outdoor and indoor environments where there is a significant radiant heat source.

Either Celsius or Fahrenheit values may be used. However, the corresponding heat category values must match the temperature units.

$$\text{WBGT} = 0.7T_{\text{wet-bulb}} + 0.2T_{\text{globe-temp}} + 0.1T_{\text{dry-bulb}}$$

For military applications, the following categories correlate to the WBGT value.

Category	WBGT °F	WBGT °C	Flag color
----------	---------	---------	------------

1	≤ 79.9	≤ 26.6	White
2	80-84.9	26.7-29.3	Green
3	85-87.9	29.4-31.0	Yellow
4	88-89.9	31.1-32.1	Red
5	≥ 90	≥ 32.2	Black

(Army Technical Bulletin Medical 507 and Air Force Pamphlet 48-152(1) 7 March 2003)

Sports, industrial hygiene, and safety organizations may utilize different values and specify different actions for the heat stress level.

# 7.0 THEORY OF OPERATION

---

## 7.1 Sensors

### 7.1.1 Temperature

A PTAT sensing element in the digital sensor has a resolution of 0.015°C and accuracy of +/-0.2 K.

Error and range checking is done to ensure accurate results.

The temperature sensing element is protected from direct moisture contact.

---

## 7.2 Electrical Architecture

A range of low power strategies are employed in GT-1 to ensure optimal low power while providing reliable and accurate measurements across the full environmental range.

A low power microcontroller is central to GT-1 performance. The microcontroller manages the sensors, performs error tests, scaling, calibration, and low-level unit conversion as required. The microcontroller also manages the Modbus protocol and other internal functions, such as EEPROM interface and bootloader functions.

The microcontroller utilizes low-power strategies, leveraging multiple low power modes and optimized code execution.

# 8.0 POWER SAVING

---

## 8.1 Run Timeout Power

GT-1 can be optimized for battery powered applications. The Run Timeout setting can be used to reduce the average operating current.

Sleep mode is controlled with the “Run Timeout” parameter. By default, the value is set to zero (0), full run mode. The default setting will be applicable for most programmable logic controllers (PLCs) since these applications are typically line powered and will not significantly benefit from power optimization.

Embedded devices and data loggers may have the programming flexibility to utilize the Run Timeout function.

Although the Run Timeout parameter range is 0 to 10000 (0 s to 10 s), the minimum actual timeout is 50 ms. Values below 50 will result in a 50 ms run time before entering sleep mode. This is a safe guard to prevent a device from becoming un-wakeable because of message transmission latency.

### Sleep Power Example

When powered at 12 VDC and a 1 s pole rate:

Run Timeout = 0 (Full Run Mode)	1.7 mA
Run Timeout = 100	< 0.45 mA

While small, the sleep power reduction can accumulate to a significant amount for a battery operated instruments. A savings of 30 mAh per day can extend system operating time and improve power budget flexibility.

---

## 8.2 Wake and Sleep Operation

Run Timeout is a millisecond (ms) count from the end of the last communication frame to initiation of sensor sleep. In other words, if Run Timeout is set to 150 the sensor will go to sleep 150 ms after the last character of a frame is received or transmitted.

GT-1 returns to full run mode when a character is received on the Modbus data port. Due to the latency in returning to full run mode, the first few characters of the Modbus data frame will be lost. If a Modbus packet is used to wake the sensor, it will need to be resent.

Following a “wake” packet, the Run Timeout value must be sufficiently long for the host to send a data request or instruction before GT-1 returns to sleep.

Embedded devices and programmable data loggers can send a character to wake the sensor. A Modbus broadcast message can be used for this purpose. A delay of only 4 ms from the first bit is required before sending a Modbus request.

---

GT-1 will wake from any character on the RS-485 data bus. If GT-1 is one of several devices on the data bus, it will wake even when other devices are addressed.

---



## 8.3 Power Down

Embedded devices and programmable data loggers may have discrete power controls to peripheral devices. If so, additional power savings may be achieved by disconnecting the supply power to GT-1. This strategy may be practical if the polling period is longer than 1 s.

The time required from power-up to first character is less than 100 ms. Modbus frames sent prior to this may not be received by the sensor.

---

# 9.0 SOFTWARE

---

## 9.1 Introduction

GT-1 is a digital sensor with on-board firmware. The firmware provides critical functions including sensor element interface, sensor value processing, calibration scaling, error detection, power management, and Modbus operation. The firmware also includes a boot loader for in-field firmware changes.

---

## 9.2 Boot Loader

GT-1 firmware may be updated in the field through the RS-485 serial data lines.

### 9.2.1 Required Equipment

RS-485 to USB (or RS-232) converter.

12 VDC power supply.

Dyacon Boot Loader PC utility.

GT-1 firmware (.hex) file.

### 9.2.2 Procedure

1. Disconnect GT-1 from the host equipment.
2. Connect the GT-1 to the PC with the RS-485 converter.
3. Connect GT-1 to a 12 VDC power source.
4. Run the Dyacon Boot Loader Utility. Configure the settings and press “Load.”
5. Watch for program completion.
6. Disconnect and return the GT-1 to service.

---

# 10.0 REPAIR AND SERVICE

---

## 10.1 Repair and Calibration

### Return Authorization

All equipment sent to Dyacon for calibration, warranty, or service should have a return material authorization (RMA) number indicated on the outside of the package. Include a detailed description of the problem and any to be performed on the returned unit.

An RMA number may be requested by phone or email.

Phone: 435-753-1002

Email: [support@Dyacon.com](mailto:support@Dyacon.com)

Normal business hours are 9 am to 5 pm. (Mountain Time Zone, GMT -0700)

## II.O SPECIFICATIONS

### TEMPERATURE

Range	-40°C to 80°C
Resolution	0.1°C
Accuracy	typ +/-0.2 K*
Repeatability	+/-0.1 K*
Time Constant	5.6 min
Long Term Drift	< 0.05 K/yr*
Sensor Type	PTAT *

\*Sensing element specs. Full response range information available upon request.

### ELECTRICAL

Power Input	5 to 24 VDC (12 VDC Nominal)
Current	1.4 mA <sub>avg</sub> at 12 VDC full run mode† 60 uA <sub>avg</sub> sleep mode‡

### MECHANICAL

Material	Copper globe with polyester coating. Aluminum and bronze fittings.
Overall (WxDxH)	13.2 x 13.4 x 13 cm (5.2 x 5.2 x 5.1 in)
Cable	4 conductor, 24 AWG, stranded Foil Shield w/ drain wire Outdoor rated cable
Total Weight	0.78 kg (1.76 lb)

### DATA

Protocols	Modbus RTU slave , RS485, half-duplex. User configurable baud rate, parity, and stop bits. 19200, N, 8,1 default.
-----------	--

### ENVIRONMENTAL

Operating Temperature	-40°C to 80°C
Storage Temperature	-40°C to 80°C
Water	Direct rain and snow.

† Continuous full run mode, reading 200 range registers once per second.

‡ Timeout set to 50 or greater. No Modbus activity.

# I2.0 MODBUS APPENDIX

Dyacon GT-1 air sensor uses Modbus RTU format. The following are the protocol details required for embedded devices to communicate with the Modbus sensor.

- Modbus data uses “big-endian” data format, 0x1234 is sent as 0x12 then 0x34.
- The CRC uses “little-endian” data format, 0x1234 is sent as 0x34 then 0x12.
- The idle time between frames must be greater than or equal to 3.5 characters. The frame inter character delay must be less than 1.5 characters.
- The PDU Registers are addressed starting at zero. Therefore a register numbered as 201 is addressed as 200.

The following is an example of a register read starting at register number 202.

Detailed protocol information is available at [www.modbus.org](http://www.modbus.org).

## Request Frame

The following is an example of a read of the globe temperature.

Field Name	Length (bytes)	Function	Example Data
Slave Address	1	Device address.	0x02
Function	1	Read holding register.	0x03
Register Start Address	2	Sensor address (201).	0x00C9
Quantity of Registers	2	Number of 16-bit registers to read.	0x0003
CRC	2	Error check.	0xC6D5

TX String (0x): 02 03 00 C9 00 03 D5 C6

## Response Frame

Field Name	Length (bytes)	Function	Example Data
Slave Address	1	Device address.	0x02
Function	1	Read holding register.	0x03
Byte Count	1	Number (N) of data bytes.	0x06
Register Data	N	Register data, upper byte first. Register 202 (Temp): 325 (32.5 °C)	0x0145
CRC	2	Error check.	0x[zzzz]

RX String: 02 03 06 01 45 02 B1 21 4E zz zz

**Error Frame**

<b>Field Name</b>	<b>Length (bytes)</b>	<b>Function</b>	<b>Example Data</b>
Slave Address	1	Device address.	0x02
Error Code	1	Error code value.	0x83
Exception Code	1	Error code values (01, 02, 03, 04)	0x01
CRC	2	Error check	0xF070

TX String: 02 83 01 70 F0

# I3.0 REVISION HISTORY

<b>Rev</b>	<b>Description</b>	<b>Author</b>	<b>Date</b>
A	Initial Release	E. Bodrero	03 May 2016
B	5.3 – Add section. 5.4 – Change default address to 4. 6.0 – Add section.	E. Bodrero	05 Oct 2016
C	Change Pictures 4.1 and 4.2 – Clarification of language	E. Bodrero	05 May 2017
D	3.1 – Correct the product description 12.0 – Correct Modbus register read example.	E. Bodrero	2021-11-18